

NO	CONTENT	DATE	REVISER	APPROVAL
△				
△				
△				

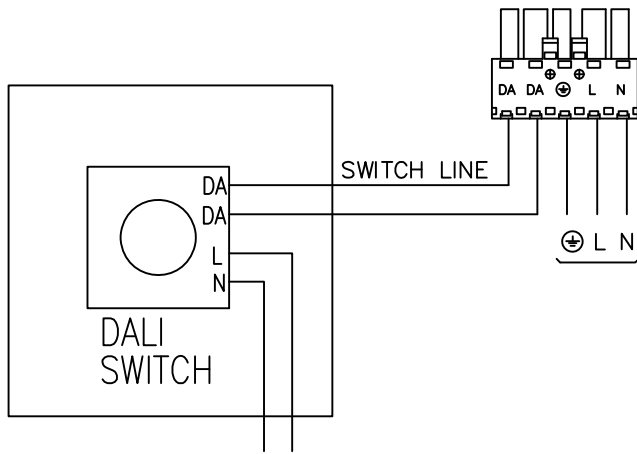
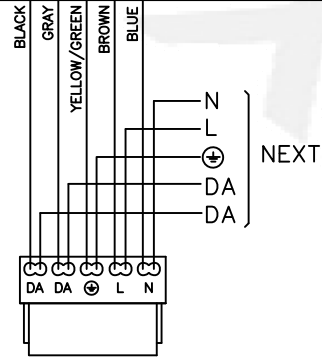
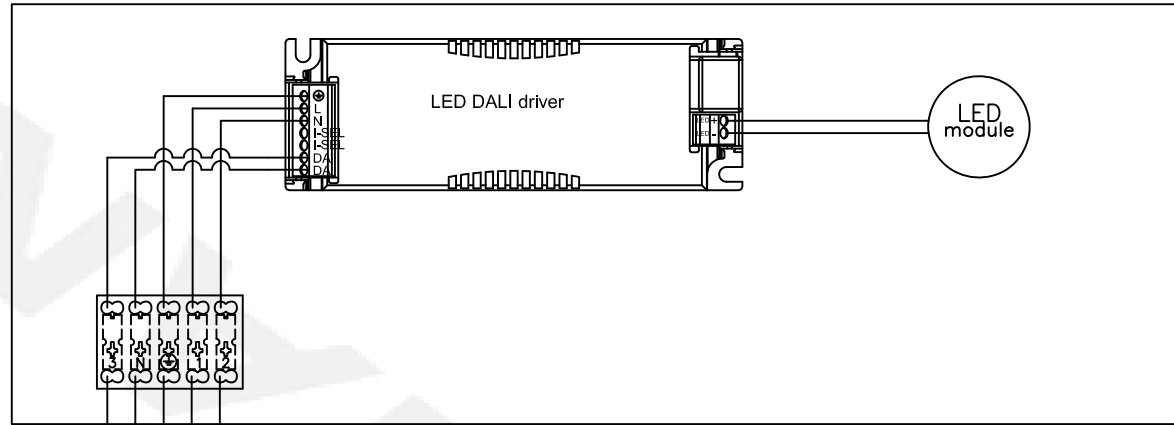

TITLE:	SCALE	N / S	UNIT	MM	NO.	REVISED
DALI DIMMING TYPE CONNECTION DIAGRAM					△	
	PROJECT METHOD	⊕	WEIGHT	KG	△	
					△	
	APPROVED	J. W. PARK			MATERIAL	ASS'Y
	CHECKED	S. M. SON			DWG NO.	
	DRAWN	B. K. HWANG			SHEET NO.	
	DATE	2023. 03. 29				3-A